

British Battleship, 1886

# COLOSSUS

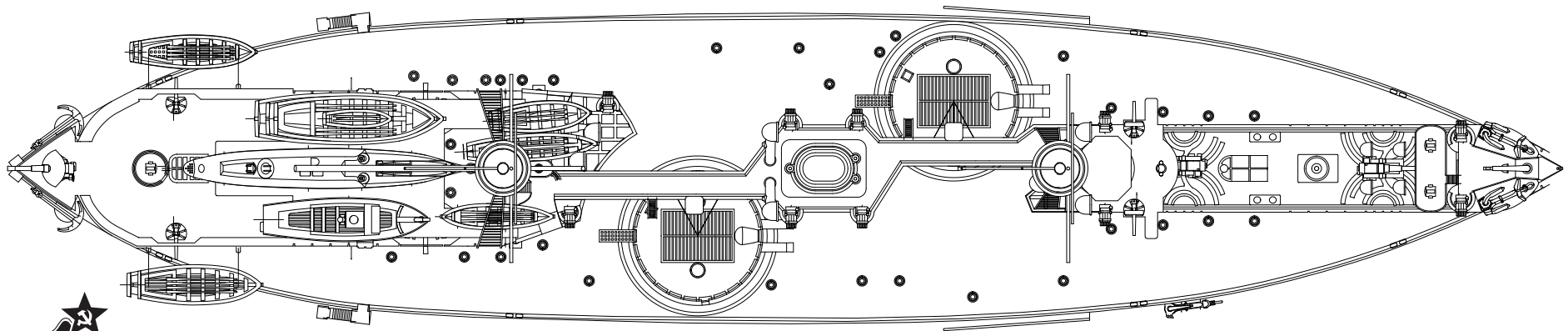

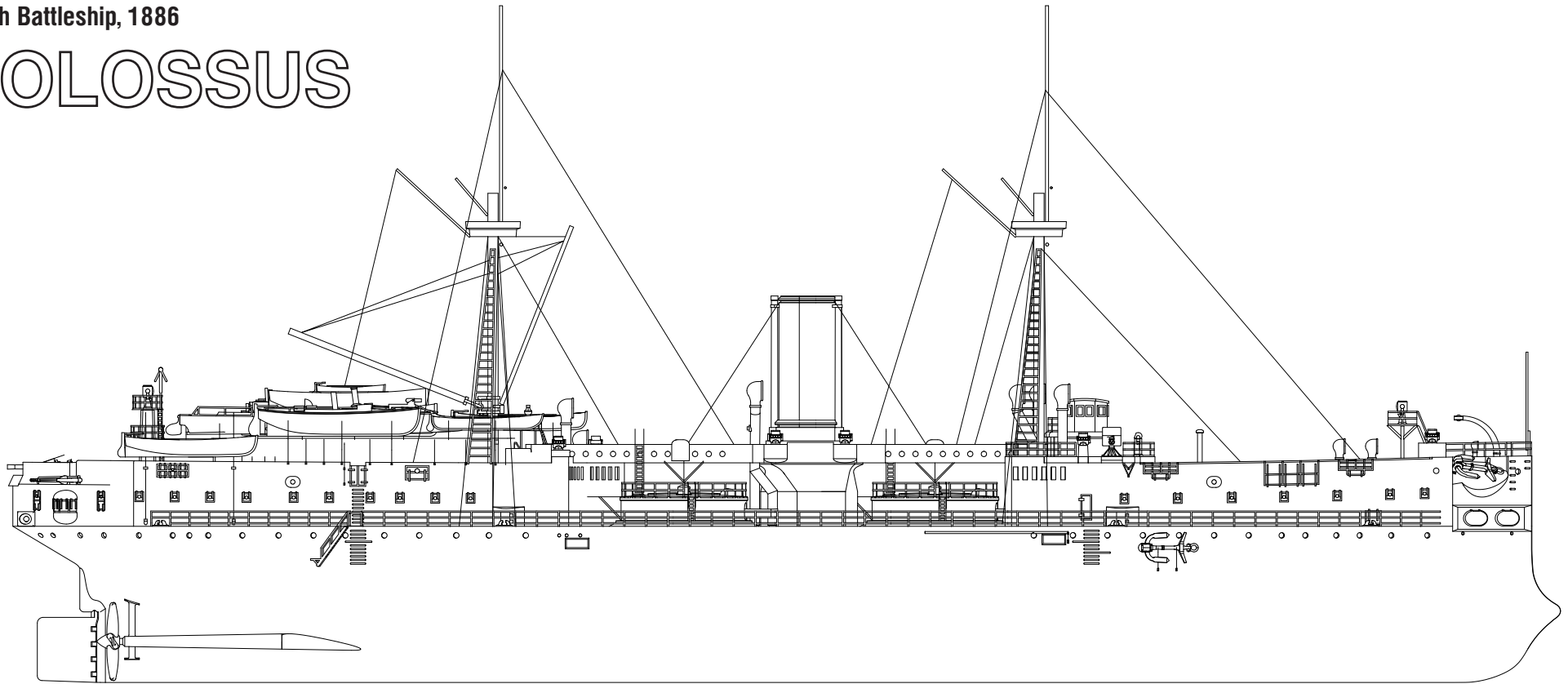
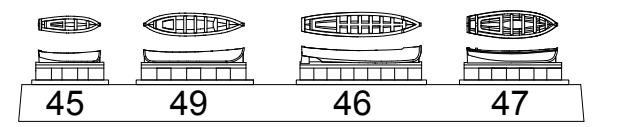
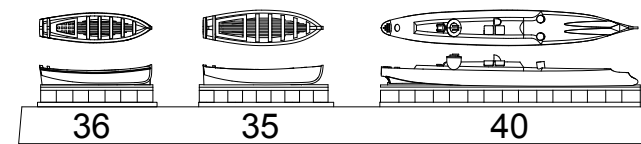
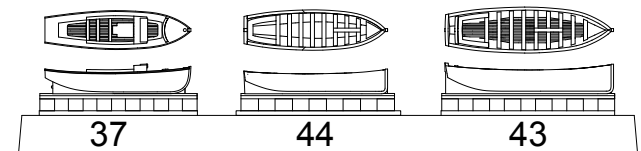
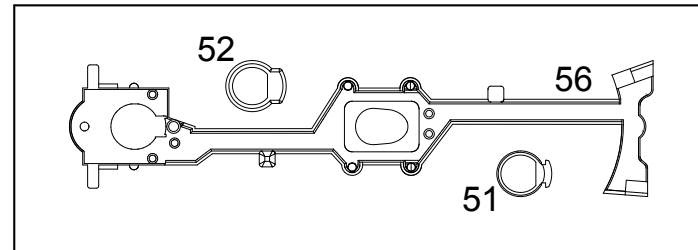
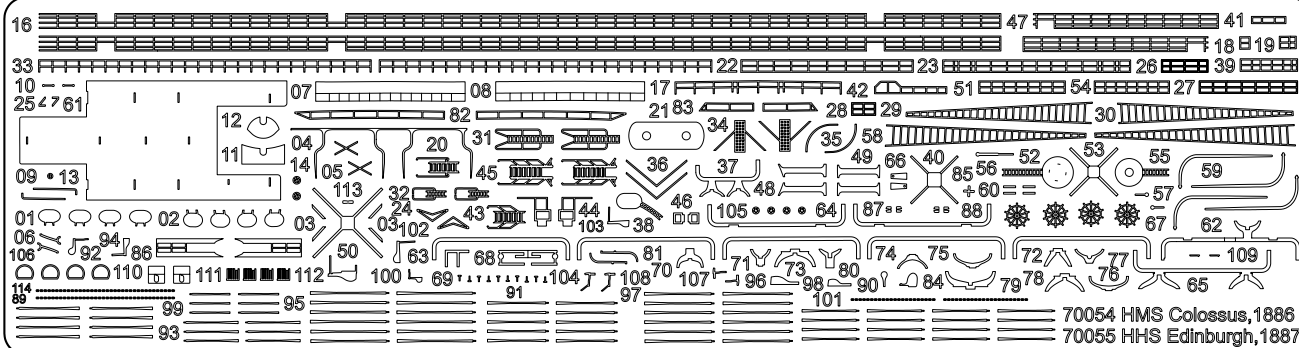

masts & yardarms  
self made parts

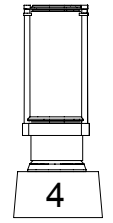
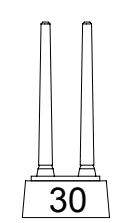
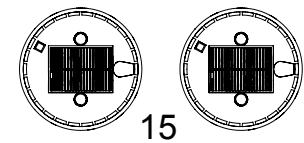
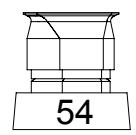
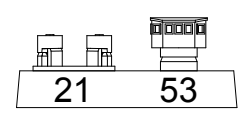
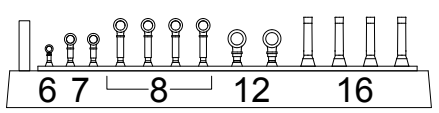
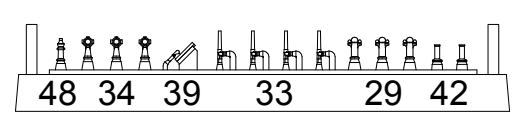
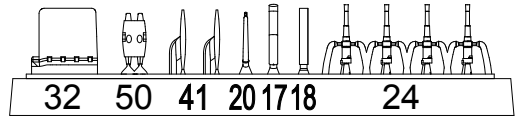
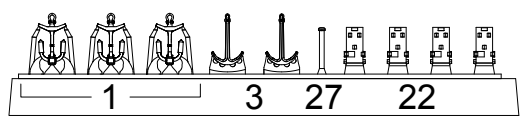
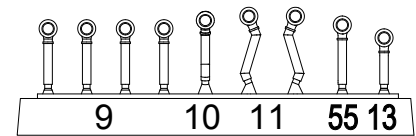
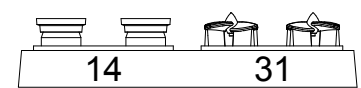
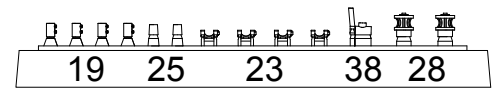
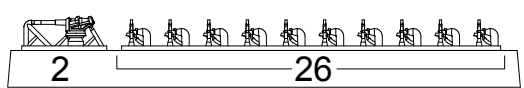
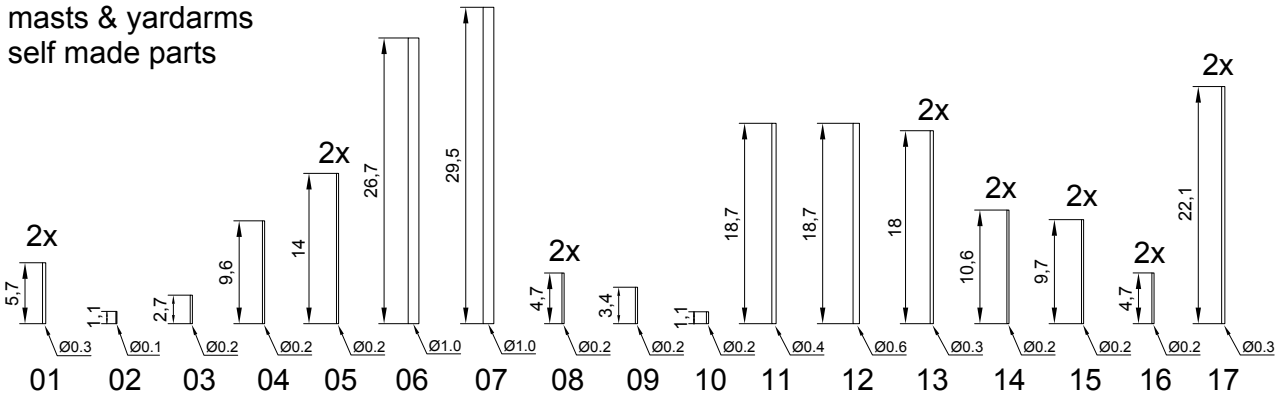

Please note that the assembly guide reflects the position of the parts when installed only, and not the exact order of the assembly.  
To download the assembly instructions in PDF (high resolution) please visit [www.combrig-models.com](http://www.combrig-models.com)

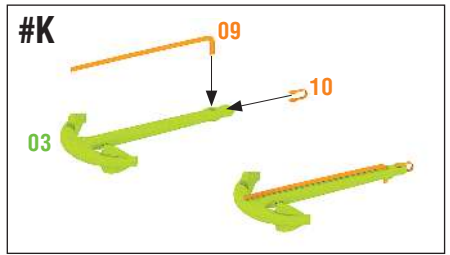
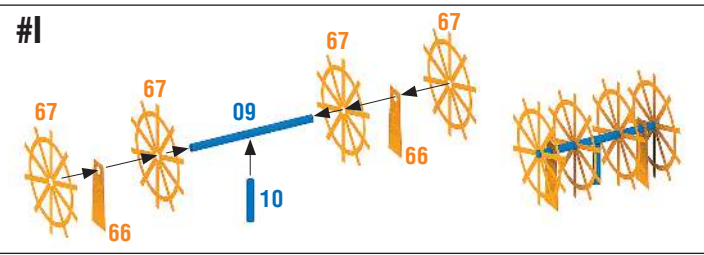
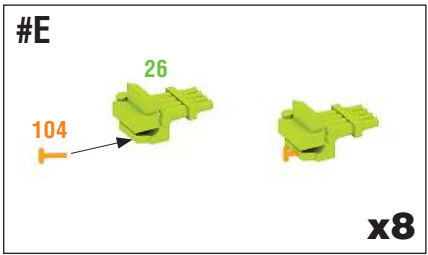
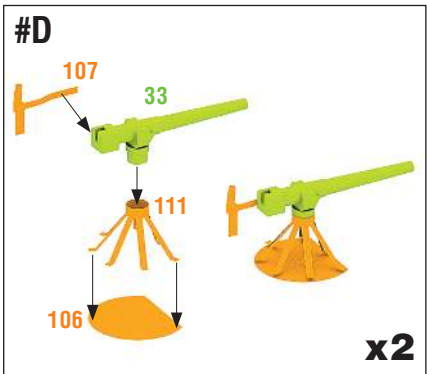
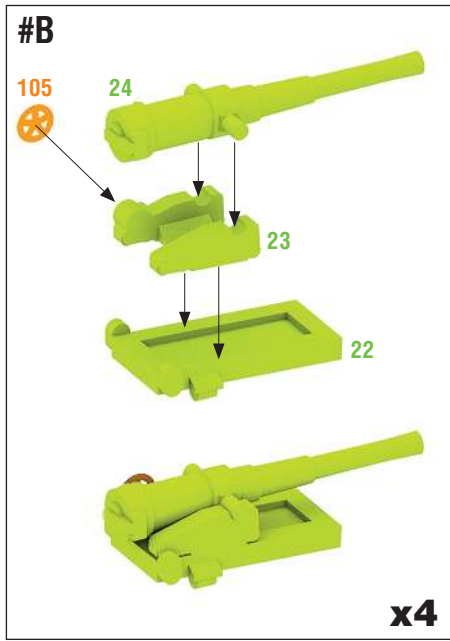
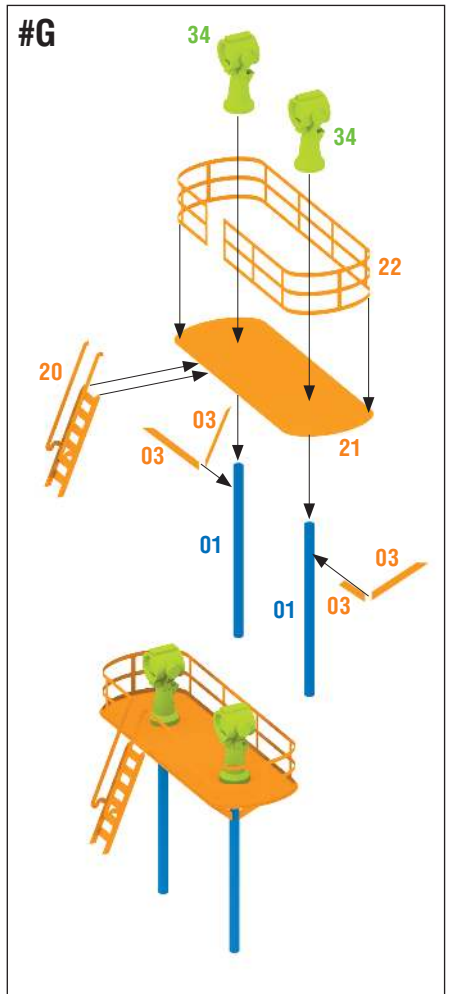
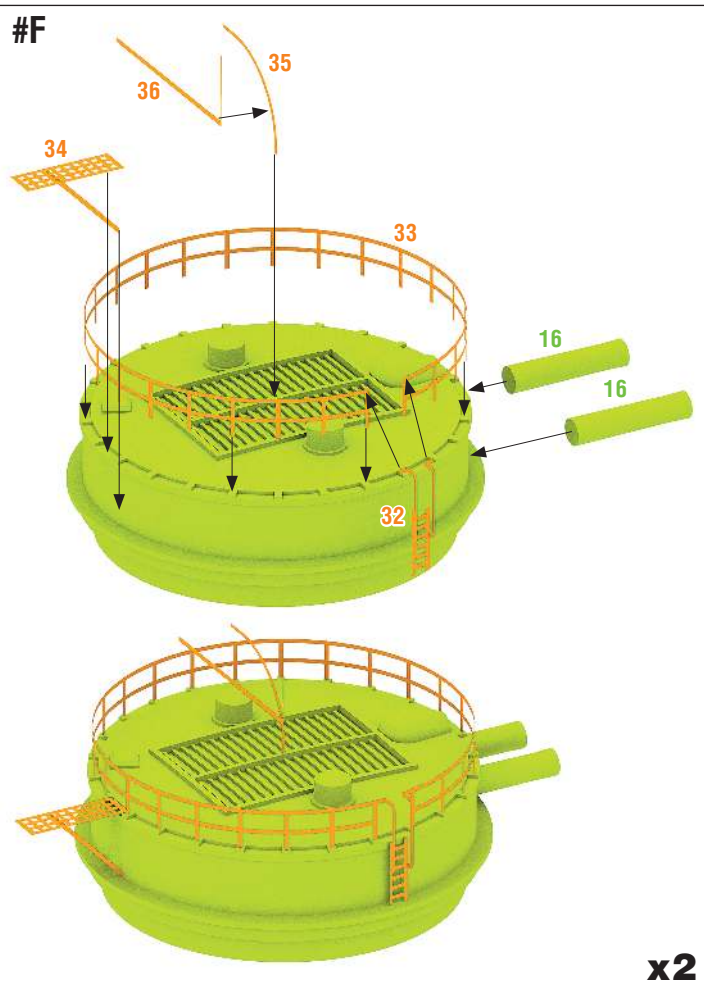
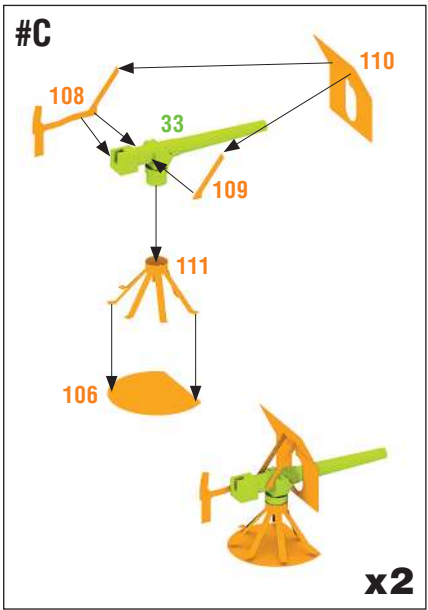
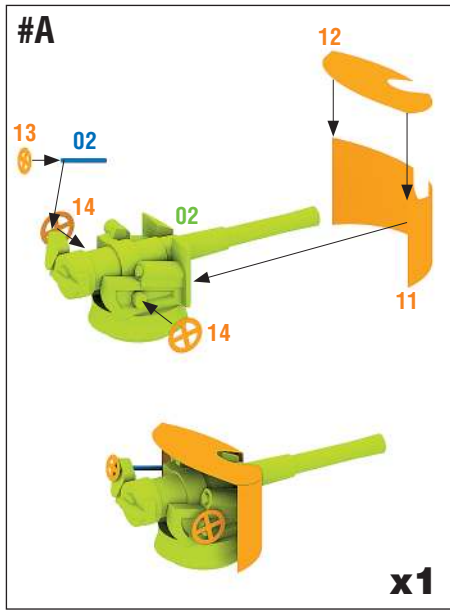

УСЛОВНЫЕ  
ОБОЗНАЧЕНИЯ:



Выполнить для левой и правой частей  
Repeat for opposite side



Выбор варианта  
Optional



Повторить операцию  
Repeat

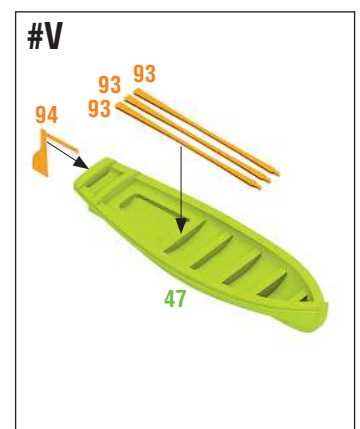
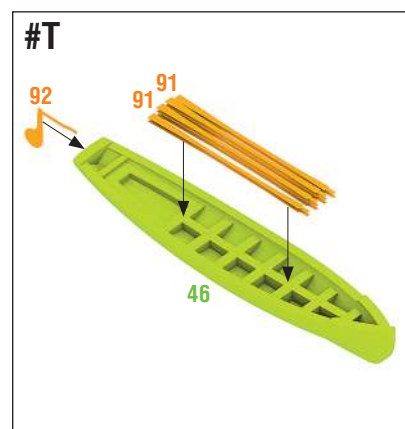
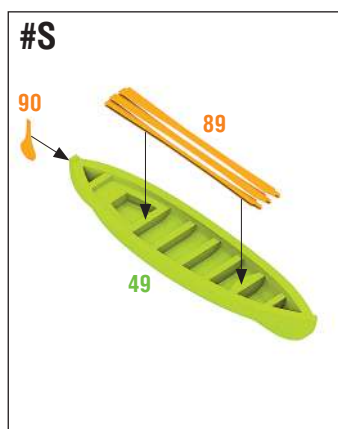
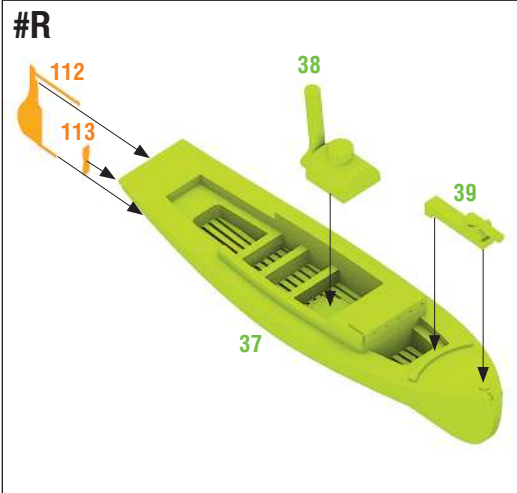
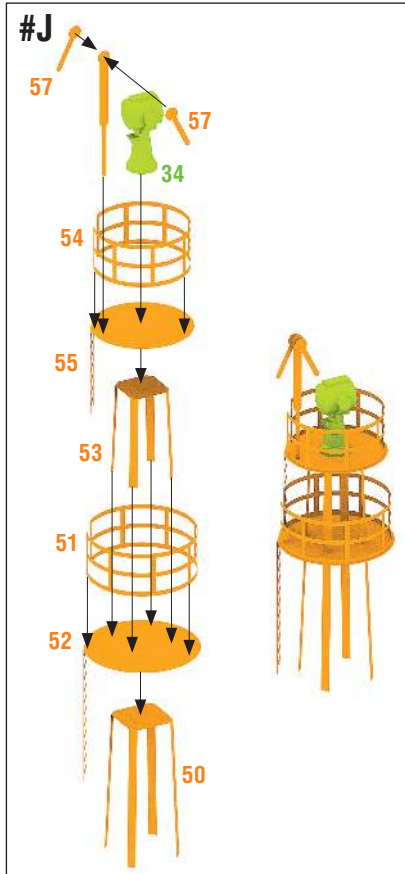
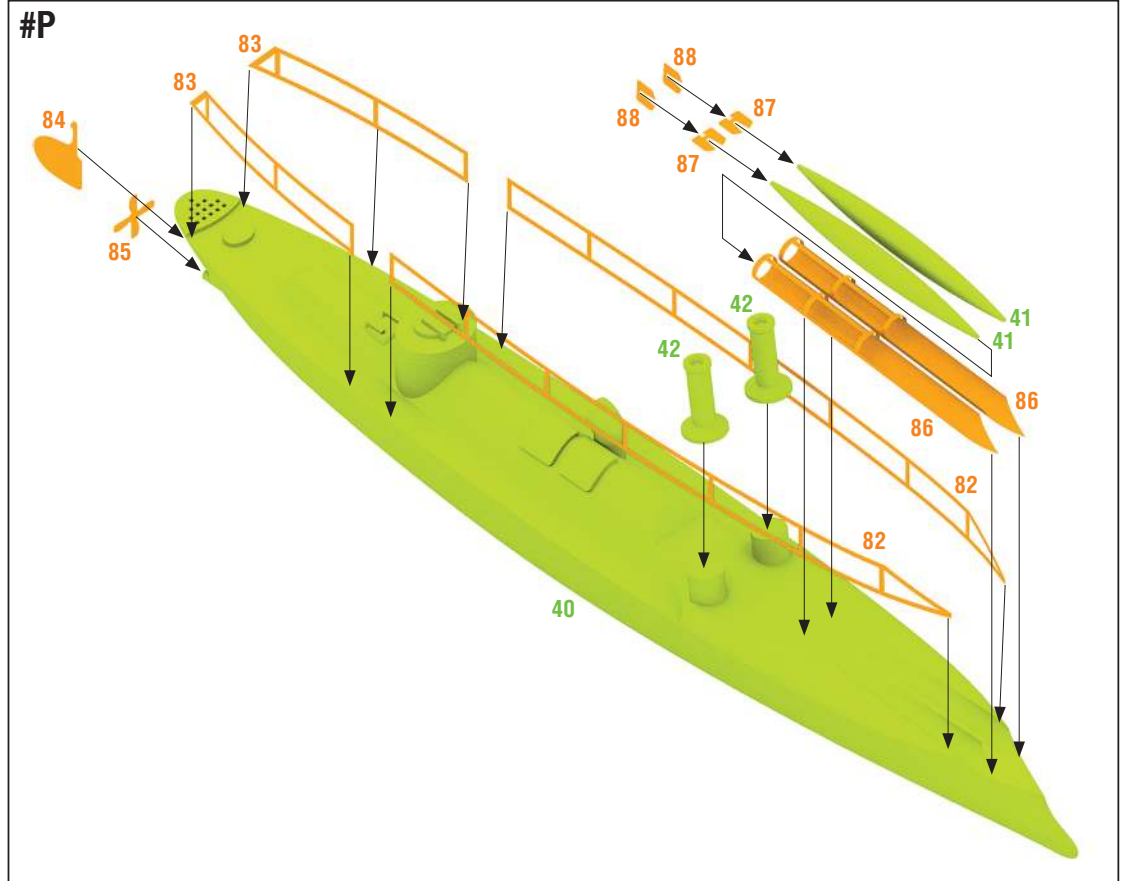
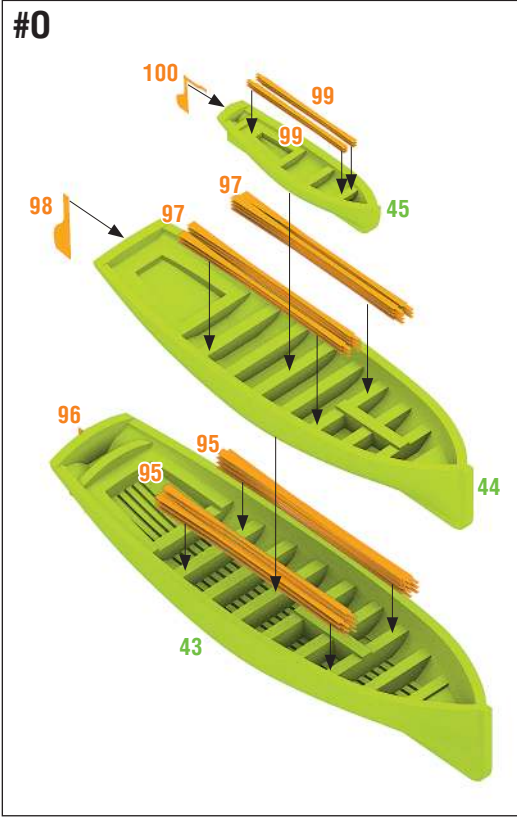
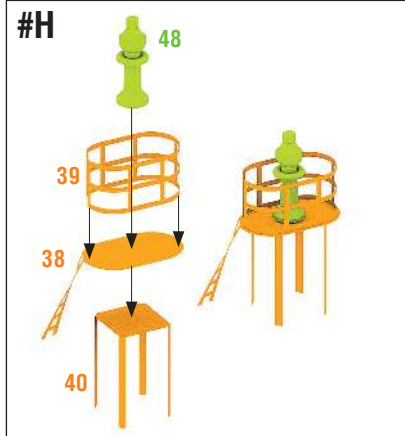

#N

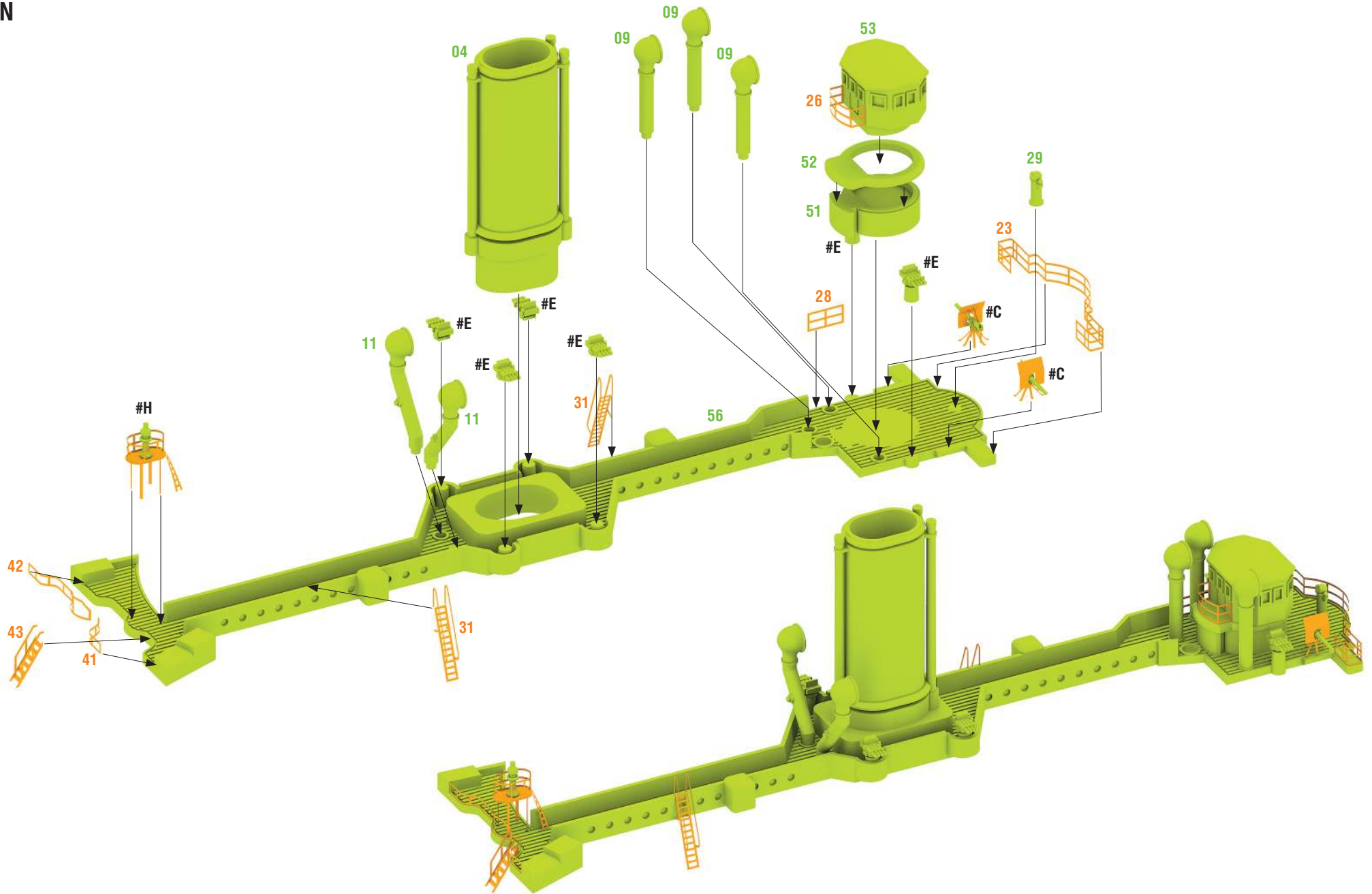

#L

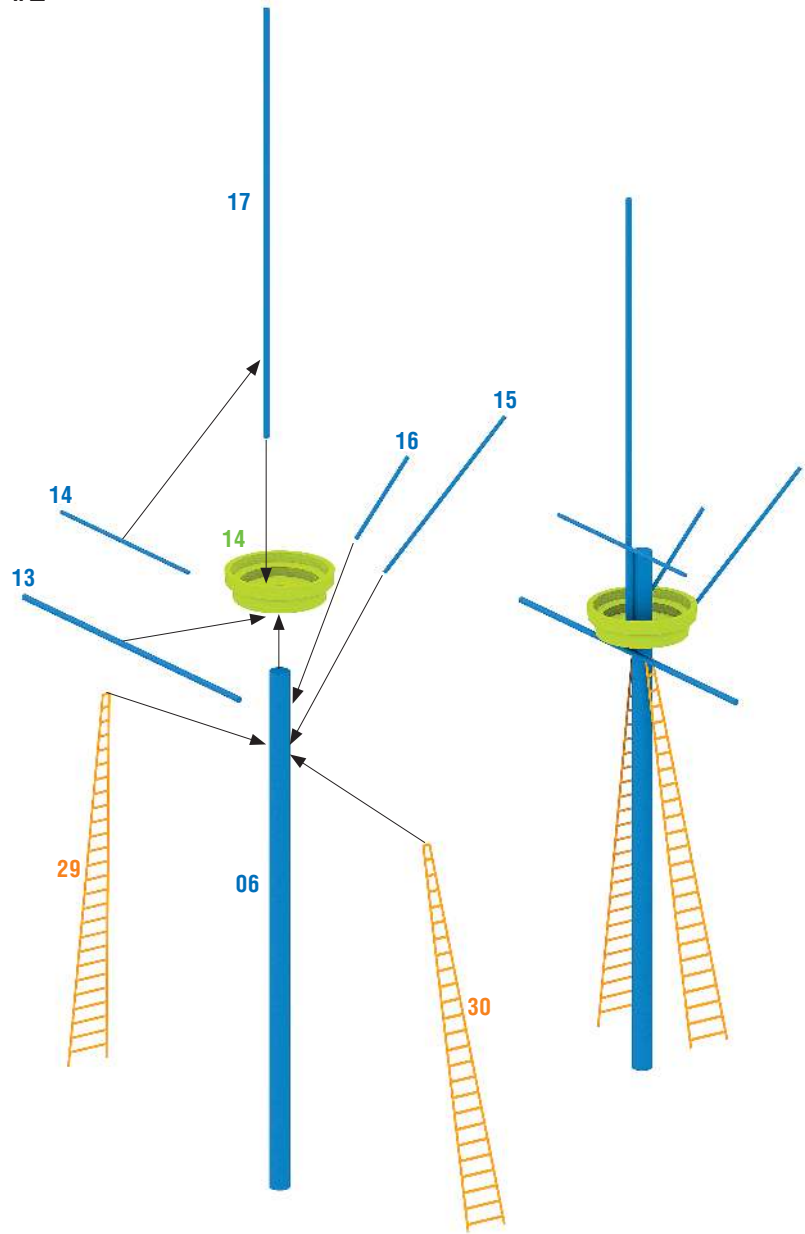

#M

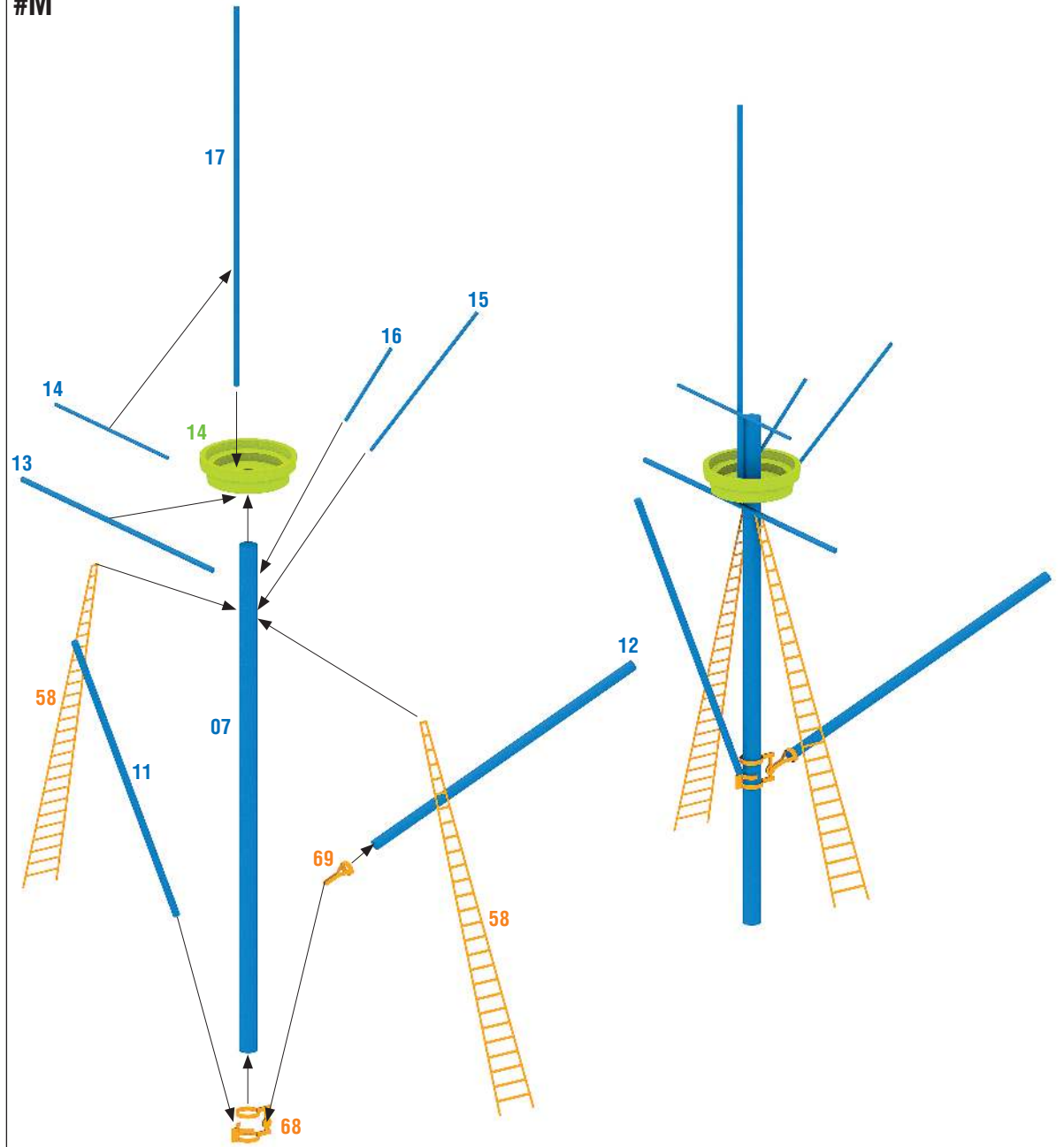

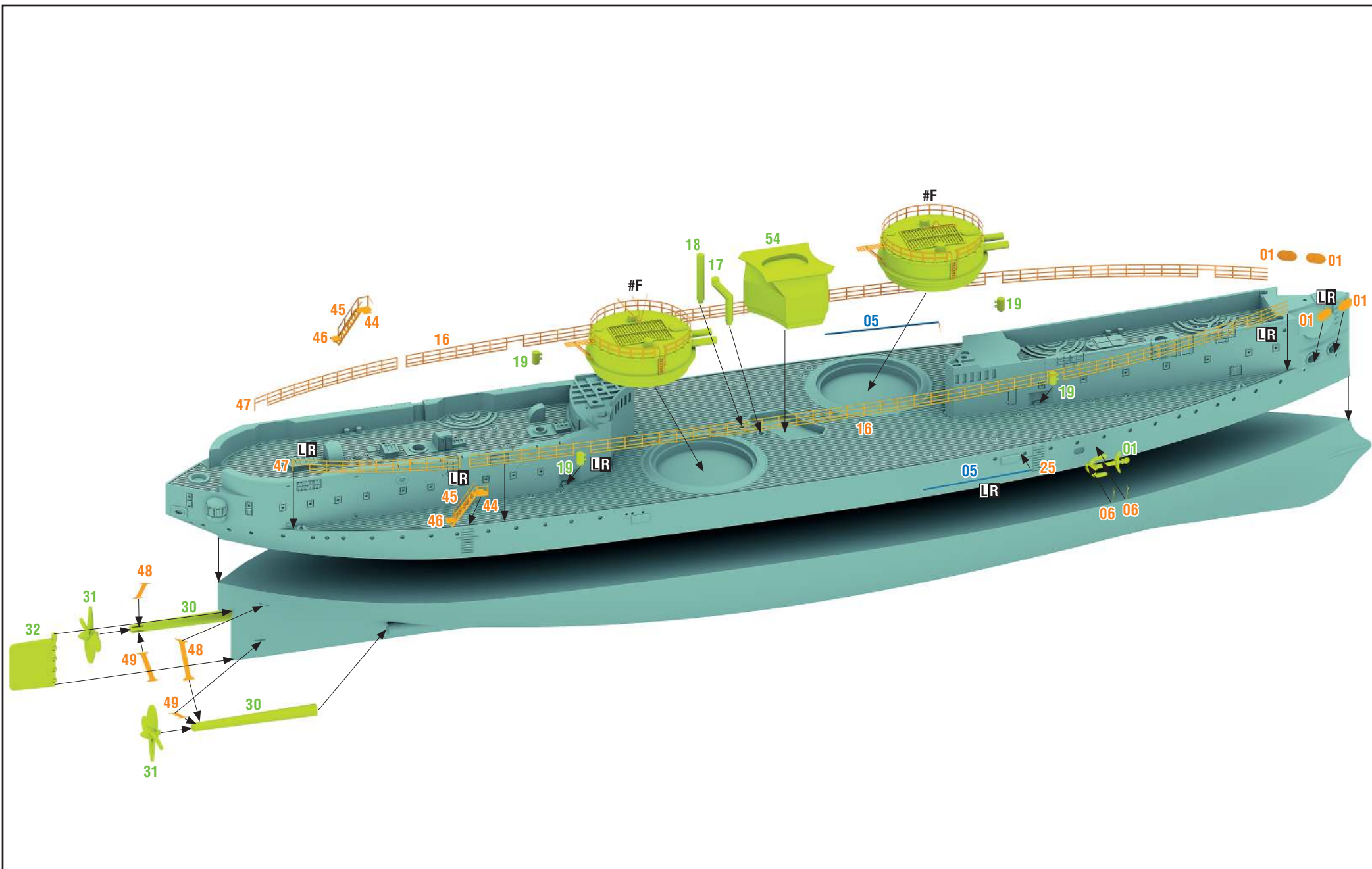

FOR FULL HULL VERSION ONLY

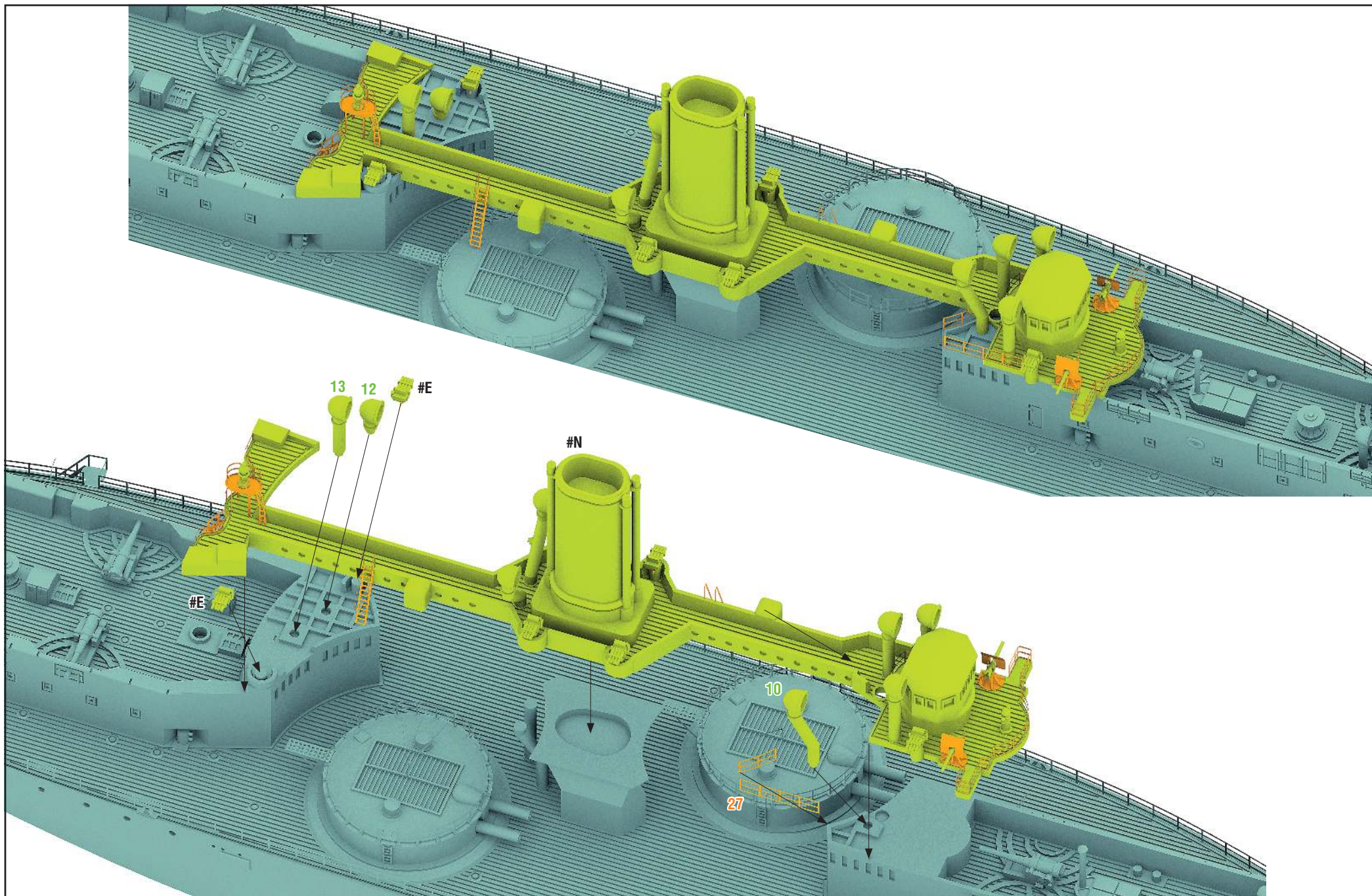



#R

